



**Te Tāhuhu o
te Mātauranga**
Ministry of Education

Great schools, great spaces

Standard designs for primary and intermediate schools

June 2026

Version 1.0

Great schools need great spaces. Warm, dry, safe and light-filled classrooms. Areas that flex to how your teachers like to teach. Buildings and spaces that feel good and belong to your school and your community. Buildings that are easy to maintain.

We have collaborated closely with architects, engineers, builders, and educators to develop designs that achieve all this — consistently and affordably. We have called these standard designs. They meet all New Zealand building requirements, make sense for most schools, and respond to your school's identity, your site, and the way your students learn.

Our plan is to keep improving these standard designs. As we gather feedback from schools, builders, and designers, we will review and update our standard designs to ensure they work for everyone.

Acknowledgements

These standard designs have been developed through the collaboration of many teams and individuals.

We thank the architects, engineers, quantity surveyors, and builders who contributed to this process. Their expertise has helped ensure these designs are practical to build, easier to maintain, and deliver quality outcomes for schools and their communities.

We also acknowledge our educator reference groups, peak bodies, and curriculum writers for their contributions and shared insights. Their feedback has helped shape designs that support teaching and learning.

This shared effort has resulted in a set of standard designs that respond to the needs of schools across Aotearoa New Zealand.

a t h f i e l d
a r c h i t e c t s
l i m i t e d
a t h f i e l d
a r c h i t e c t s
l i m i t e d
a t h f i e l d

Architecture



MARSHALL DAY
Acoustics

Engineering



Quantity Surveying

JASMAX

**MCKENZIE
HIGHAM**
ARCHITECTS

mesh
we engineer.

aurecon

Beca

Project Management

Introduction

What this guide covers

This guide features a range of standard designs for primary and intermediate schools, covering new teaching, library and administration (admin) spaces. It shows the available choices you can tailor to meet your school's needs and how we will work with you to make those decisions.

It does not cover every school building type or technical requirement. Our [website](#) has more detailed information about these options, including technical drawings of teaching spaces for primary and intermediate schools.

How to use this guide

Use this guide to understand:

- › the journey from planning to construction and handover
- › what decisions are made during planning
- › what layout and building material options are available
- › what your school can choose and help shape
- › what is already set in place by the standard designs.

Your project team will work with you to talk through the parts that apply to your project. Not every option in this guide will apply to every school or site.

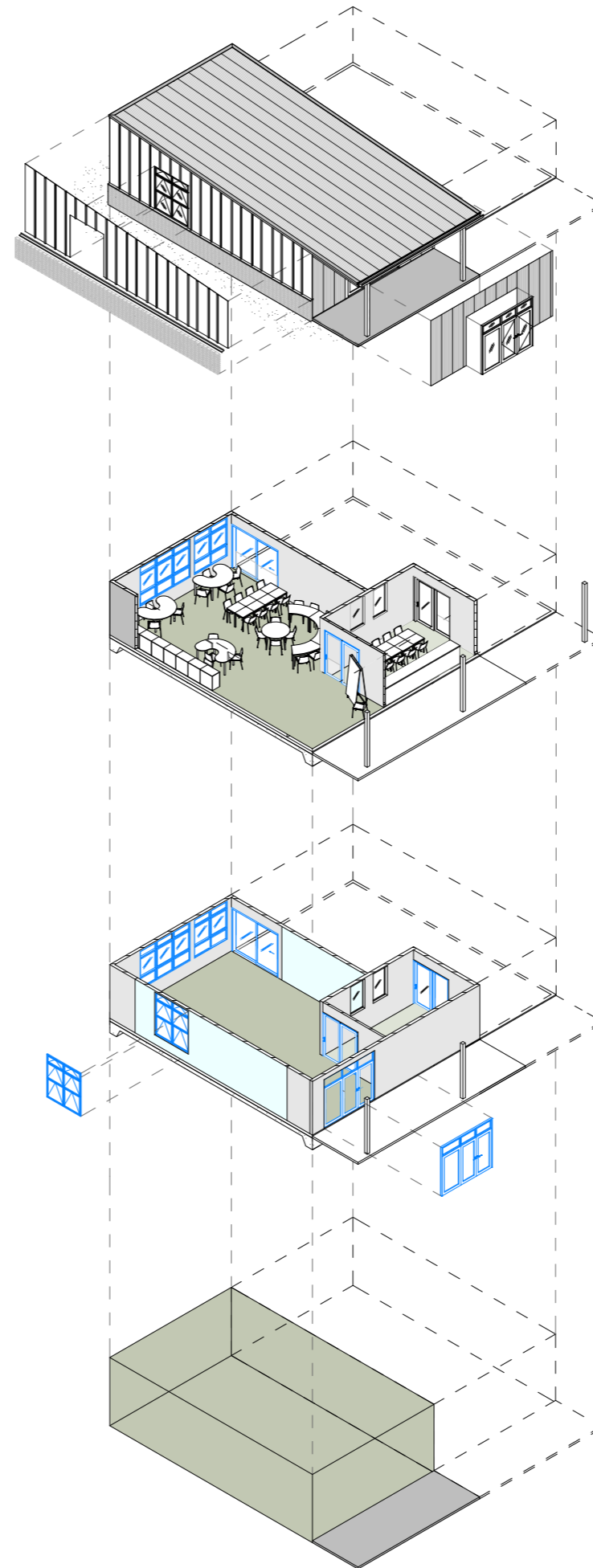

Delivery



Finishing choices

The colours, finishes, and some materials and connections and other details you can choose from that help the building fit with the rest of your school.



Layout options

The internal classroom and amenity arrangements you can choose from to get the best fit for your learning environment.



Standard designs

The building types, modules and systems you can choose from with our help.

Planning

Planning

How we understand your needs, school site, and option preferences.

What this means for your school

Standardisation for clarity, cost, speed and quality

Using standard designs means your school can expect:

- › a clearer process from planning through to handover
- › open and clear communication from us at every stage of the process
- › faster delivery because the key design work has already been done
- › high-quality learning spaces
- › layout options that we know work well, based on what we've heard and learned that best supports student learning.

Some parts of the design — such as structural systems, roofing, acoustic design, ceiling heights and window dimensions — are standard because they help us to better manage cost, quality and delivery time. But other parts can be chosen by you, so the final building works for your site, your students and your way of working.

Choices to reflect your community and kaupapa

'Standard' does not mean the same. Within these design options, your school has choices — about building placement, how spaces are arranged, what materials best reflect your community and kaupapa, and how your buildings flow and connect with the rest of your environment.

Planning for your site

Every school site is different. During planning, we work with you to look at how a new building will fit into your wider school environment.

This includes:

- › connection to other interior and exterior learning spaces
- › existing buildings and heritage features
- › services and drainage
- › sunlight, shade, trees, and wind protection
- › ground conditions
- › future development of your school.

Planning also considers how the building can reflect your school's identity and kaupapa, and support mātauranga Māori where appropriate. The aim is to make the standard design work well in your school and wider community, both now and into the future.

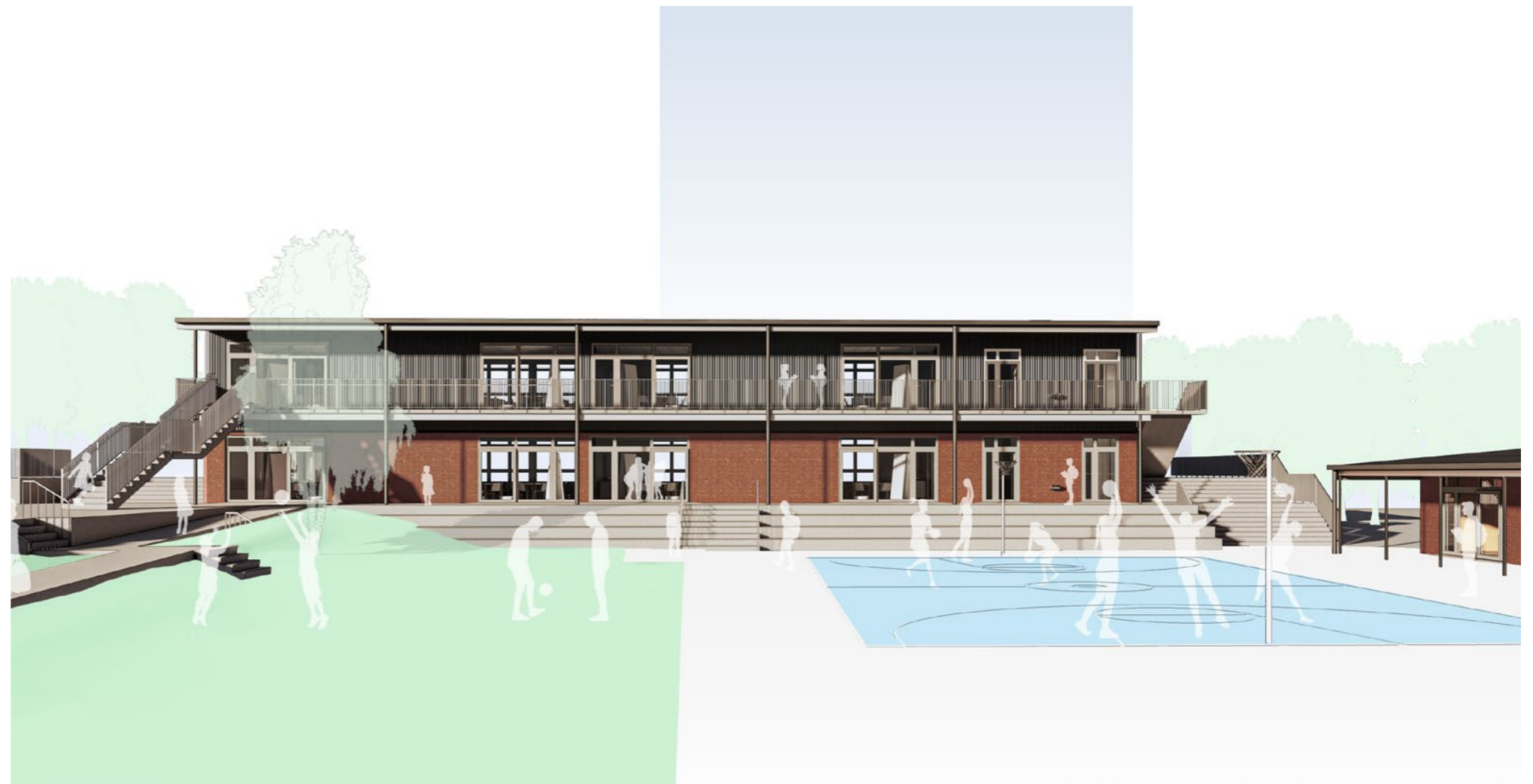

Choosing the right building

Standard building types give us a reliable and consistent starting point for new school buildings. Choosing the right type of building for your school depends on your student roll, site, existing buildings, and future plans.

For many primary schools, a single-storey teaching block will be suitable if there is enough space. On tighter sites, a two or three-storey option may be more suitable. In some cases, relocatable buildings may be the best fit for the need, site or timeframe.

Typologies

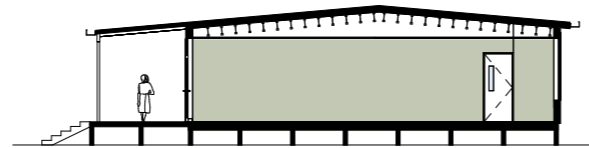

S1 - Single-depth, single-storey (gabled roof)
2-6 teaching spaces

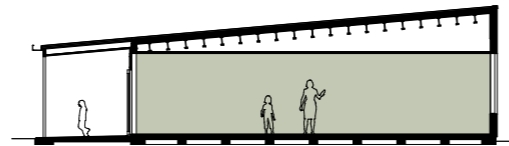

S1 - Single-depth, single-storey (typical)
2-6 teaching spaces

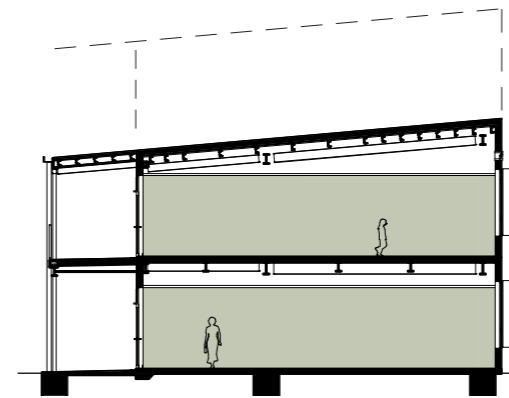

S2 - Single-depth, two-storey
S3 - Single-depth, three-storey (shown dashed)
6-18 teaching spaces

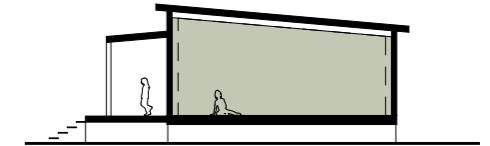

OMB 2.5 - Relocatable, single-storey
1-4 teaching spaces

Typical plan

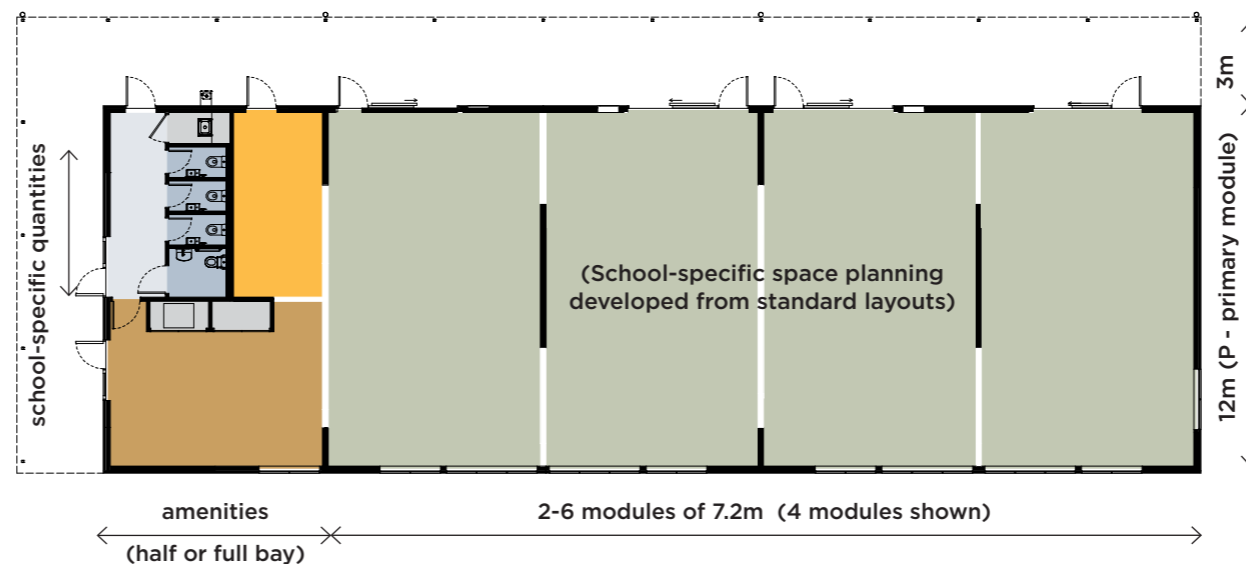

Typical floor Plan - S1 (S2, S3 multi-storey similar)

SCALE 1:200 at A3



How our building modules work

Standard designs are a series of modular building blocks that can be added and organised to create a building that is suitable for a school's needs. This gives schools choice and flexibility based on proven designs to ensure buildings are well planned, consistent, and delivered efficiently.

A teaching module provides a full teaching space with some extra area for resources as needed. Amenity modules can provide toilets, resources, admin or support spaces, depending on the agreed project scope and what already exists on your site. We also have standard modules for stairs, window shading, bag storage and other supporting elements. Over time, we may develop more standard modules as we identify needs.

Modules and examples

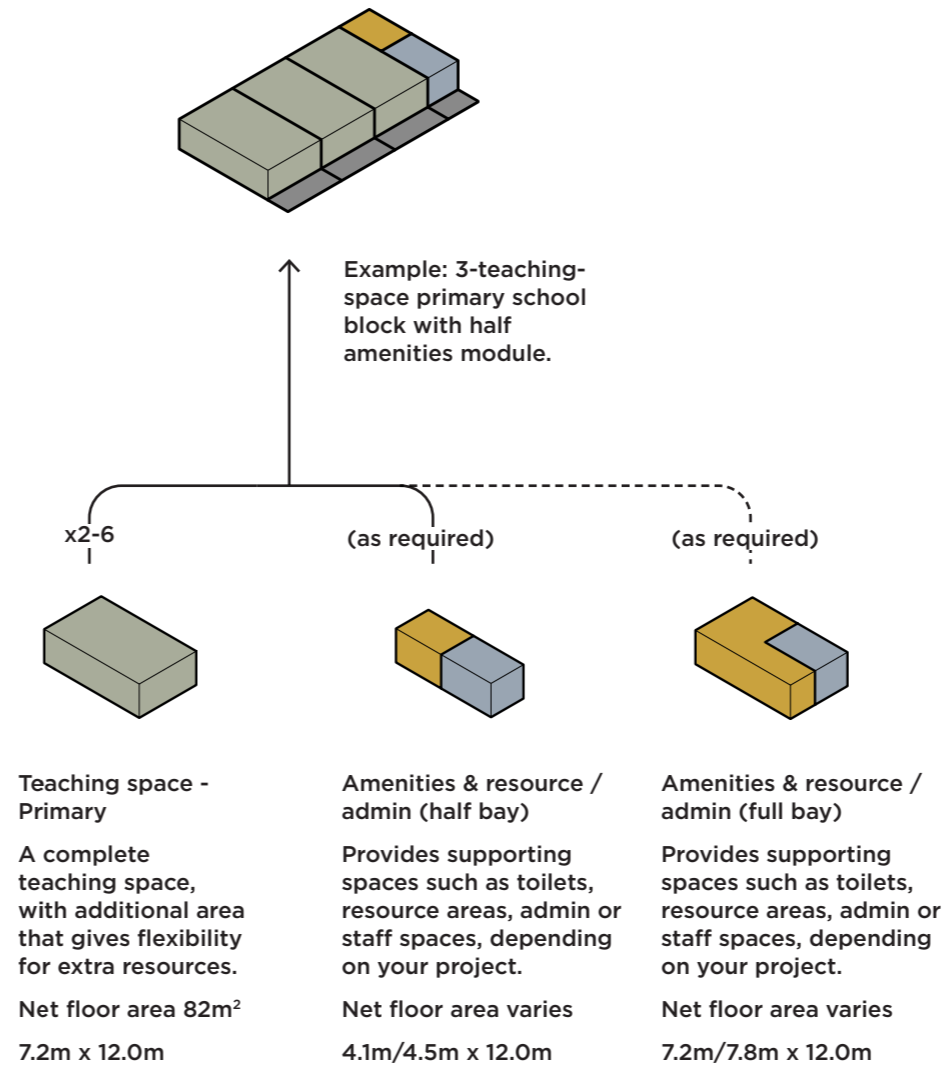

x6-18 x1 per level x1 per level

These modules can be combined in different ways to suit your site and your school's particular needs.

Additional modules support how the building works day-to-day, such as stairs, verandahs, shading and storage.

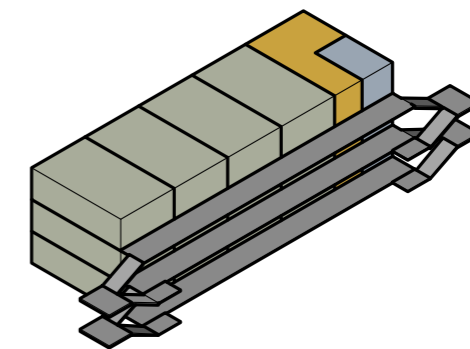

Example: 12-teaching-space primary school block with full amenities module.

Note: Three-storey block shown. Two-storey block similar. Full amenities bay can be located on end, or centrally to suit site and layouts.

Choosing teaching space layouts

Teaching spaces can be arranged in different ways to support your school's teaching and learning practices. The standard layouts show a range of options, including:

- › open teaching areas
- › wet areas
- › breakout spaces
- › areas for storing resources
- › connections between classrooms.

Your project team will work with you to help choose the layout option, or combination of options, that best supports your students, staff, and day-to-day needs.

Each layout module is based on a detailed brief that summarises a school's needs, and prioritises different ways of teaching and using space. These briefs outline the typical equipment and resources used in classrooms and helps ensure there are practical, usable zones to support teaching and learning.

If you feel these layouts don't fully meet your education needs, we will work with you to ensure your practices are supported in your new building.

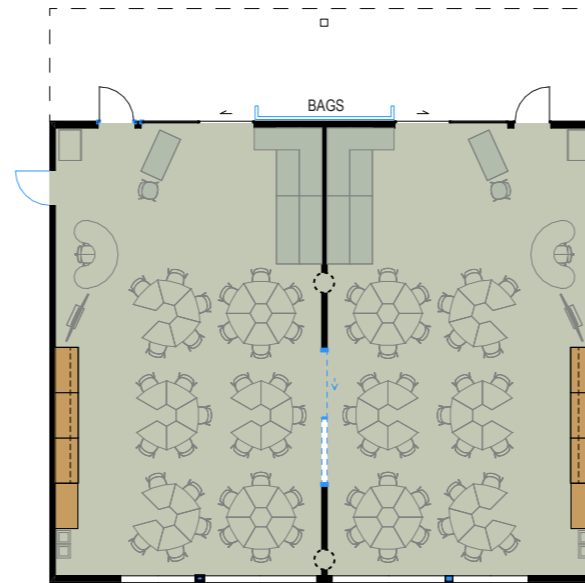

Layout A
General teaching with tiered seating

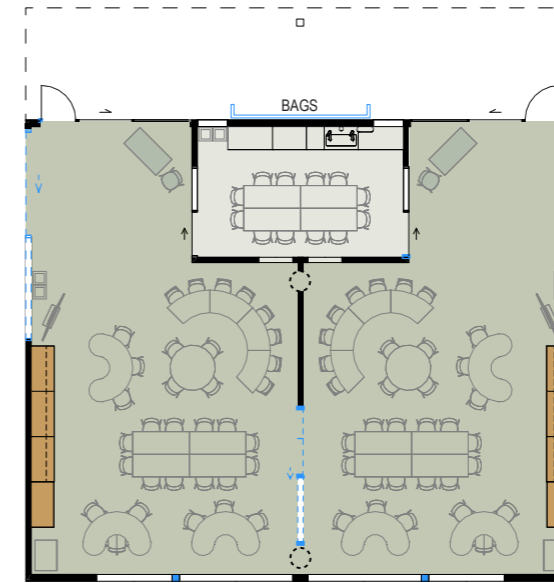

Layout B
General teaching with shared enclosed wet space

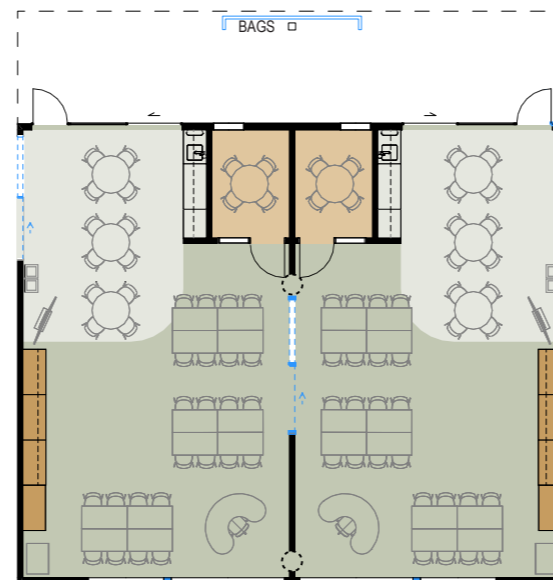

Layout C
General teaching with small breakout room, wet area in teaching space

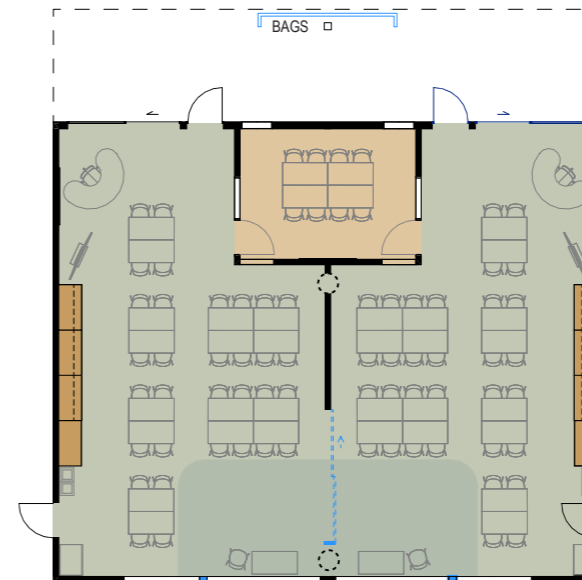

Layout D
General teaching with shared breakout room

Legend

- General teaching
- Wet area
- Resource / teachers wall
- Breakout space
- Optional sliding doors
- Indicative furniture (school-supplied)
- Column (where multi-storey)

SCALE 1:200 at A3
0 1 3 5 10m

Examples: Teaching spaces

These examples show how teaching, amenity, and support modules could be combined to respond to a sample site. These are not the only possible arrangements. We will work with you to confirm what arrangement works best for your school.

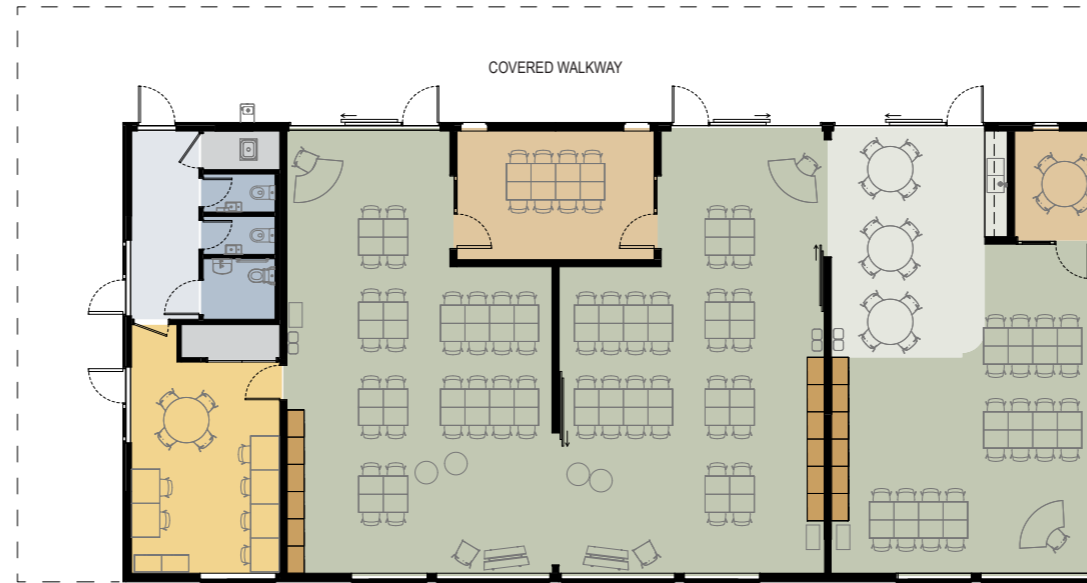

Example A - 3 teaching spaces, single-storey (S1)

Cellular teaching spaces with opportunity for interconnection, plus half-bay amenities

Legend

- General teaching space
- Wet area
- Resource / teachers' wall
- Breakout space
- Admin & resource space
- Indicative furniture (school-supplied)
- Column (multi-storey)
- Service / emergency-access door

SCALE 1:200 at A3

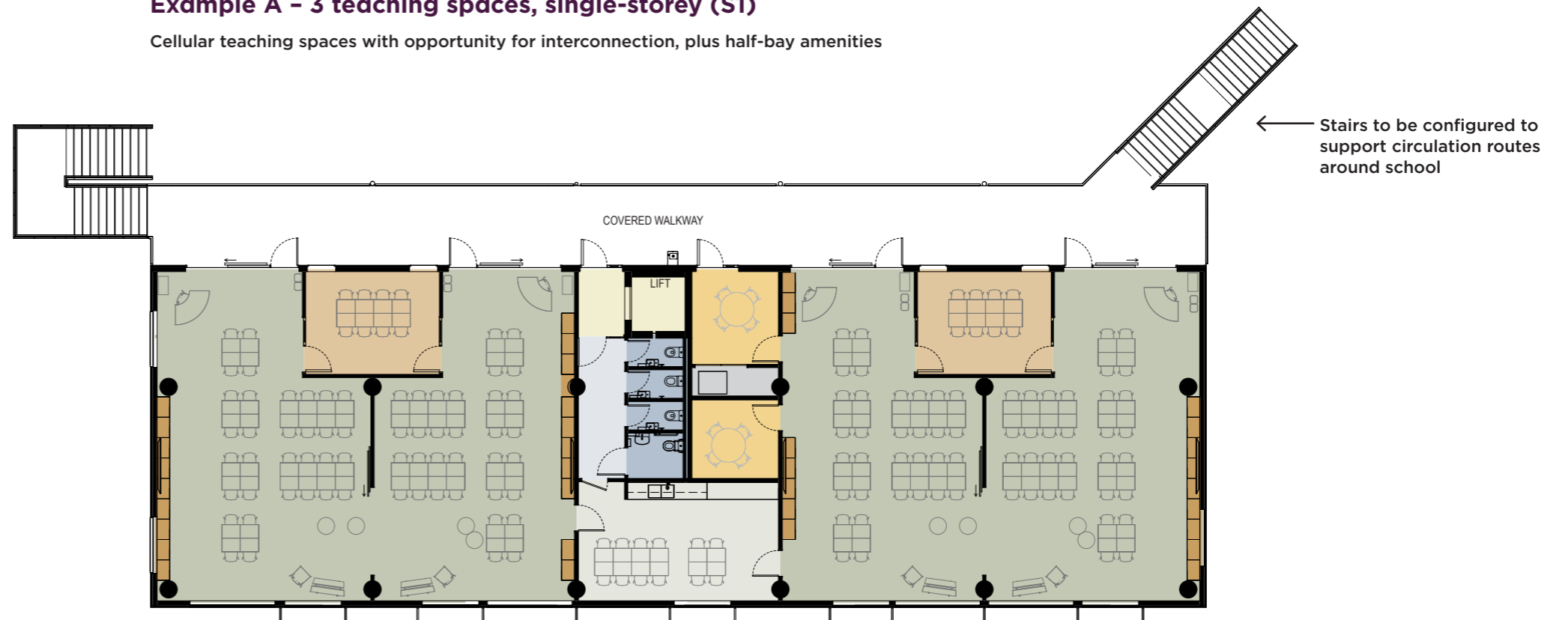

Example B - 4 teaching spaces per level, multi-storey (S2 or S3)

Paired or connected teaching spaces with shared wet space; full bay amenities (upper level plan shown)

Choosing library layouts

Standard library layouts have been designed for different school sizes. They are based on the same module system as the teaching spaces, which helps make the design easier to plan and deliver.

If a library is part of your project scope, we will work with you to confirm which layout best suits your student roll, site and wider school plan.

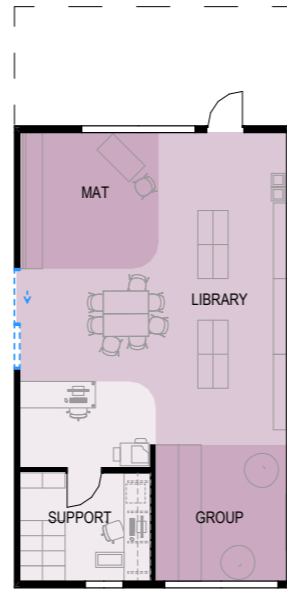

Layout A

1-module, library for a small-to-medium primary school

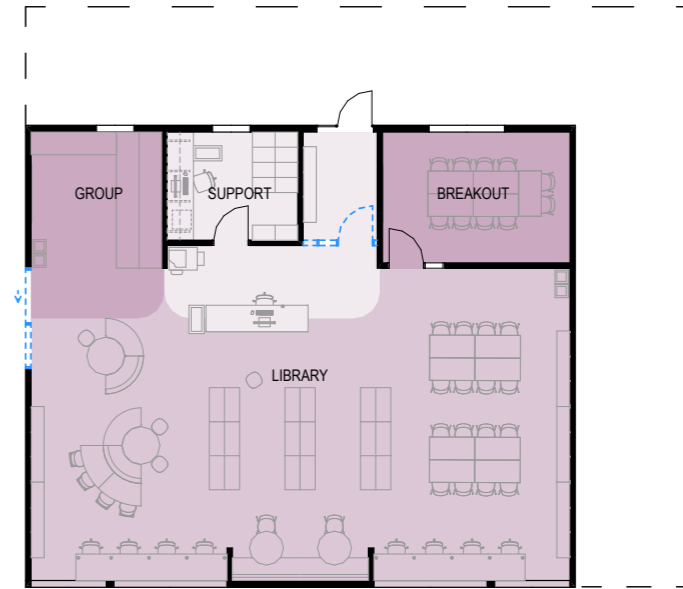

Layout B

2-module, library for a large primary school

Legend

■ Library

☺ Indicative furniture (school-supplied)

SCALE 1:200 at A3
0 1 3 5 10m

Choosing administration layouts

Standard admin layout examples are available for different school sizes. These layouts include spaces that support the day-to-day operation of a primary school, such as reception, sick bay, meeting rooms, staff areas, workrooms and leadership spaces.

Administration layouts can be adjusted to suit how your school operates and what you currently have on site. Note that intermediate admin examples are not included in this guide. You can use our briefing templates to define your school's specific needs.



Layout A
2-module, administration for a small school



Layout B
3-module, administration for a medium school

Legend

- WC
- Admin
- Internal Circulation
- Indicative furniture (school-supplied)

SCALE 1:200 at A3
0 1 3 5 10m



Layout C
4-module, administration for a large school

Choosing materials & finishes

Your school will be able to choose from a range of materials and finishes that have been proven in school environments. These selections are included to help the building better align with your school's identity, while supporting long-term maintenance and value for money.

A range of other material choices are listed in this table. However, some choices may be limited by climate, orientation, durability, maintenance, cost or technical requirements etc. Your project team will help guide you through these options and finalise which ones will work best for you.

	Element	Options you can choose from	Finishes you can choose from
Exterior	Wall cladding	A - Profiled metal cladding	Standard range
		B - Brick or concrete masonry veneer	Standard range
		C - Painted fibre cement	Wide spectrum of paint finishes
	Roofing	NA (metal-clad warm roof)	Standard range
	Exterior windows and doors	NA (powder-coat finish aluminium frames)	Standard range
	Balustrade	A - Vertical open balusters	Hot-dip galvanised (HDG) finish or, HDG with paint finish
		B - Perforated infill panels	Hot-dip galvanised (HDG) finish or, Powdercoat finish over aluminium
	Bag shelter	Where contextually required	NA
Glazing manifestation (also interior)	NA (vinyl applied to glazing)	School-specific design	
Interior	Teaching-space layout	A - Open-plan with tiered seating	NA
		B - Shared wet medium breakout	
		C - Integrated wet area with small breakout	
		D - Shared dry medium breakout	
	Wall linings	A - Dado at low level, pinboard above	Standard range
		B - Full-height pinboard	Standard range
		C - Pinboard to door head, paint above	Standard range
		D - Dado, pinboard, paint above	Standard range
	Dry-floor finishes	NA (carpet tile)	Standard range
	Wet-floor finishes	NA (vinyl)	Standard range
Inter-class connection	Openings from standard types	Standard range	

Exterior materials & finishes

Exterior materials and finishes help define how a building looks, performs, and weathers over time. Standard exterior materials provide durable, cost-effective solutions that respond to different sites, climates, and school environments.

Your school can choose from a range of materials and colours to reflect your identity and how the building fits within the wider school environment.

Standard exterior claddings include profiled metal, brick, and painted fibre cement. These can be used in different ways, depending on building height, location, and environmental conditions.

Windows, doors, balustrades, roofs, and shading elements are also standardised to ensure quality, safety, durability and long-term performance.

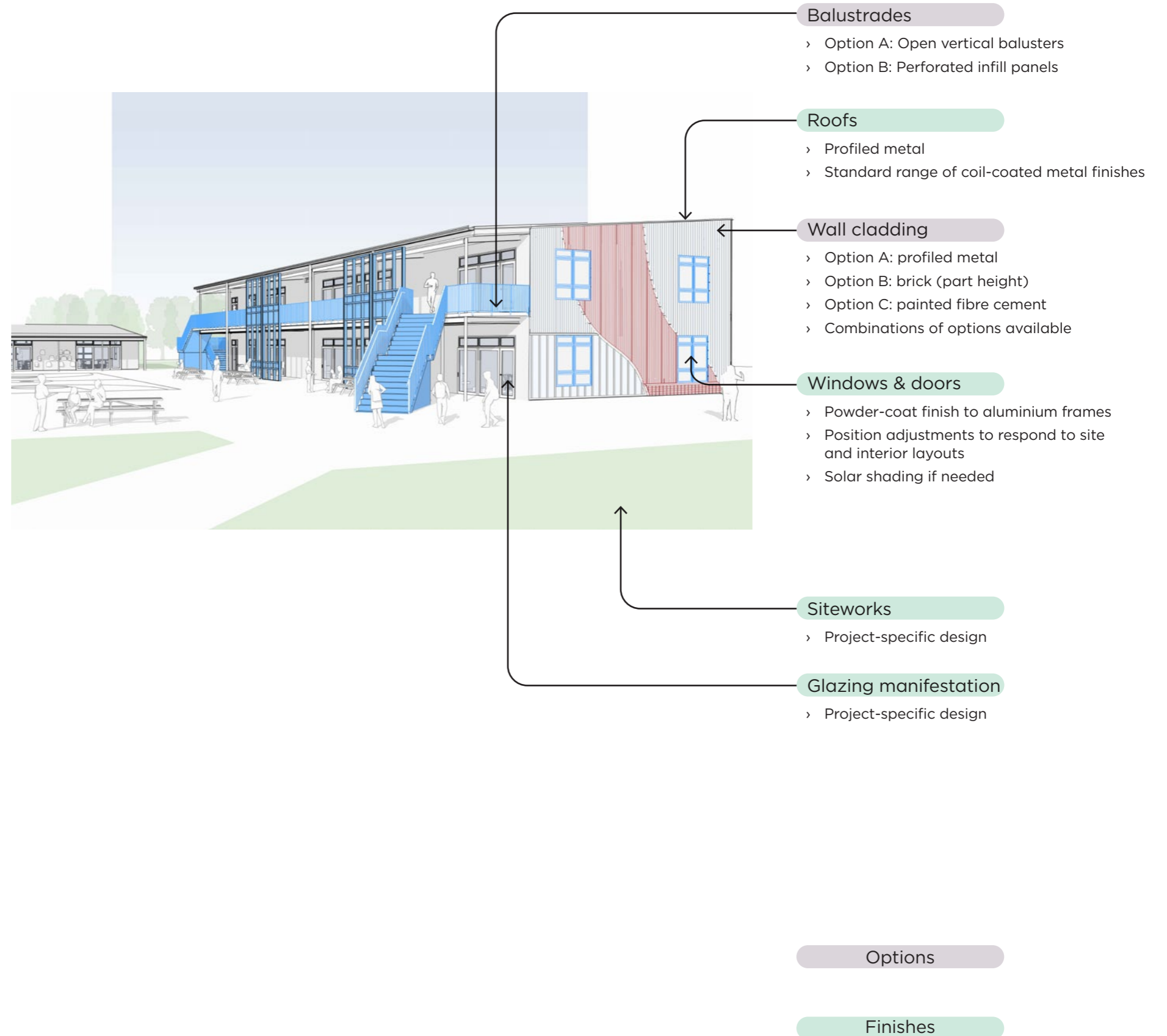

Exterior cladding

Choosing cladding

Your project team will work with you to choose cladding from the available options, taking into account:

- › the building type and height
- › the local climate and exposure to weather
- › seismic and structural requirements
- › long-term maintenance and durability
- › how the building fits within the wider school environment.

Not all cladding options are suitable in every situation. Some combinations may be limited by site conditions or building configuration.



Option A: Profiled metal

- › Profiled metal cladding (ie corrugated, trapezoidal) from standard ranges
- › Factory-coated metal (ie Colorsteel, Colorcote)
- › Finish based on standard proprietary colour ranges within MoE requirements

Finishes

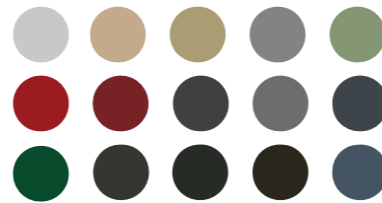

Option B: Brick

- › Brick or concrete masonry veneer cladding
- › Use at low-level only (refer examples below)
- › Use in combination with fibre cement (single storey only) or profiled metal at high level where applicable
- › Finish based on standard ranges



Option C: Painted fibre cement

- › Medium-density fibre cement sheet with vertical cover battens
- › Use at low-level only (refer examples below)
- › Use in combination with profiled metal at high level for multi-storeys
- › Paint finish in wide spectrum of colour ranges within MoE requirements



Above: Profiled metal cladding
Below: Veneer brick cladding



Above: Painted fibre cement
Below: Veneer brick cladding



Above: Profiled metal cladding
Below: Painted fibre cement



Profiled metal cladding



Above: Painted fibre cement
Below: Veneer brick cladding



Veneer brick cladding (low-seismic zones only)

Examples



Profiled metal cladding

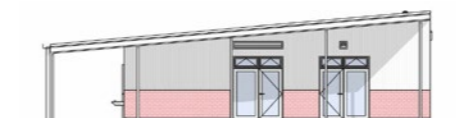

Above: Profiled metal cladding
Below: Veneer brick cladding



Painted fibre cement

Examples: Exteriors

These examples show how standard exterior materials and finishes may be used in different combinations. When selecting colours and finishes, it's important to consider sunlight, glare, heat gain, and how the building relates to its surroundings. Some colours may be limited if they affect building performance or durability.

These examples are illustrative only. Final selections will be confirmed with you during the design process.



Option A: Profiled metal

- › Full-height profiled metal cladding
- › Bag shelters to suit climate
- › Open painted balustrade



Option B: Brick

- › Low-level brick cladding (full height on single storeys in low seismic areas only, but brick dado possible in all areas)
- › Profiled metal cladding on upper level of multi-storey above brick
- › Open natural-finished balustrade



Option C: Painted fibre cement

- › Painted fibre cement cladding
- › Profiled metal cladding to upper level of full-height two-storey walls
- › Infill balustrade panels
- › Bag shelters to suit climate

Interior materials & finishes

Interior materials play an important role in how teaching spaces feel, function, and perform. Standard interior materials balance durability, ease of maintenance, cost, and comfort.

Your school will be able to choose finishes that reflect your identity and support how your spaces are used.

Using Furniture, Fixtures and Equipment (FF&E) funding

The detailed primary classroom layouts on our website explain what's included in the base build and what's purchased using FF&E funding.

[Furniture and equipment funding for state schools](#)

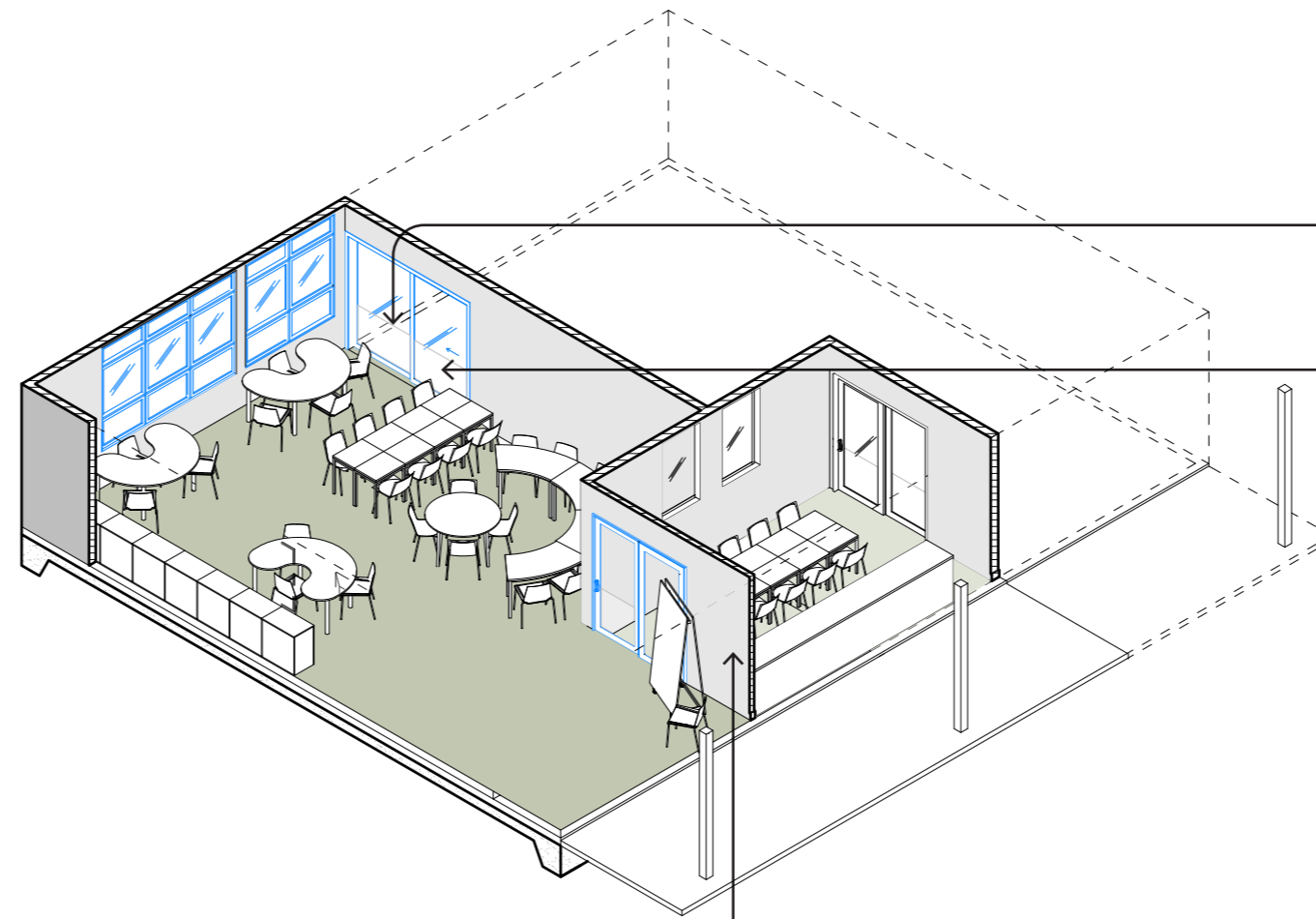

Glazing manifestation

- › Project specific-design

Inter-class connection

- › Sliding and swing doors from standard types
- › Option for full opening up to 7m wide where required



A. Solid door for access only



B. Single glazed sliding door over sidelight



C. Double glazed sliding doors over wall

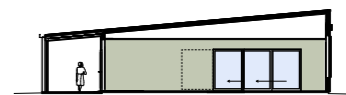

D. Triple glazed sliding doors over wall

Wall linings

- › Mix of high-wear timber-panel dado and/or acoustic pinboard lining
- › Option for paint-finished plasterboard at high level only
- › Finishes based on standard ranges

Wet-area flooring

- › Vinyl
- › Finish based on standard ranges

Dry-area flooring

- › Carpet tile
- › Finish based on standard ranges

Options

Finishes

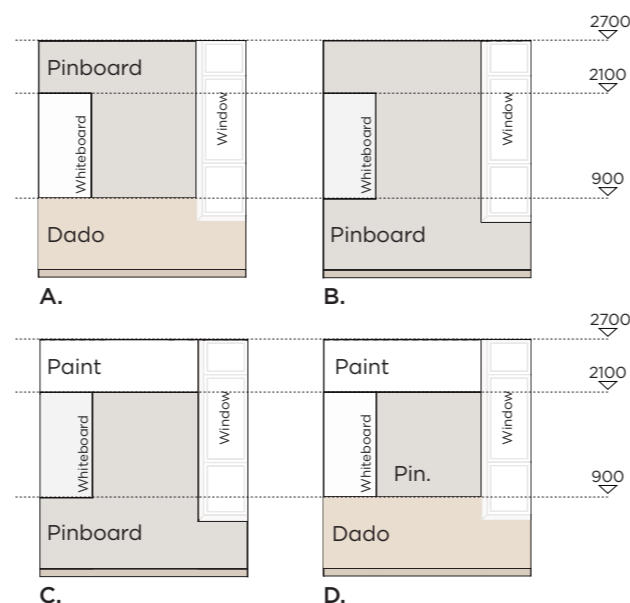

Examples: Interiors

These examples show how standard layouts, materials, and finishes can be combined to create practical and welcoming learning spaces.

These examples are illustrative only. Final selections will be confirmed with you during the design process.



Option A:

- › Tiered seating around mat area
- › High-wear dado, pinboard above
- › Connection with adjacent teaching space via glazed sliding doors



Option B:

- › Dry teaching space
- › Full-height pinboard
- › Connection to shared wet space



Option C:

- › Wet area integrated into teaching space
- › Small breakout space off teaching space
- › High-wear dado, with accessible pinboard above

Daylight, ventilation & comfort

Natural light

Standard designs are developed to provide good natural light under typical site conditions.

During planning, we consider how the building is positioned on your site — including orientation, nearby buildings, and trees. This helps to ensure that spaces feel bright, comfortable, and usable throughout the day.

In most cases, the standard design will already meet daylight requirements. Where site conditions are more constrained, the project team may review lighting levels to confirm that the spaces will still perform well.

Heating and ventilation for comfort

Standard designs aim to provide comfortable learning spaces year-round, using simple, efficient systems.

The preferred approach combines natural ventilation with straightforward heating. This works well in most climates and helps reduce cost, energy use, and long-term maintenance.

We also consider your climate zone and site conditions when planning. We take into account the six climate zones across Aotearoa | New Zealand and consider local environmental constraints such as noise. In some situations – such as colder climates or noisy locations – alternative heating and ventilation systems may be needed.

Services

We will work with you to understand any existing infrastructure and services already in place. This includes discussing your current systems and any suppliers you may already be working with, so we can factor these into the project. Examples include:

- › ICT
- › Security
- › PA systems
- › fire alarms.



'Colder climates' are a consolidation of Climate Zones 4, 5 and 6 as defined by the New Zealand Building Code (NZBC).

Heating & ventilation

NZBC climate zones 1, 2 & 3

NZBC climate zones 4, 5 & 6

Default

This is the standard approach for most schools. It provides a simple, effective solution that works well in typical site and climate conditions and is the starting point for all projects.

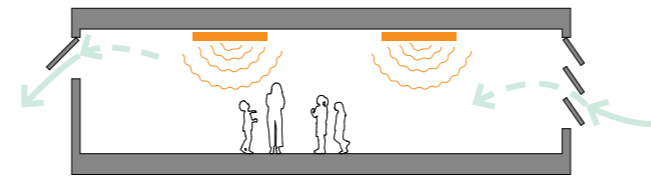

Electric ceiling radiators and natural ventilation.

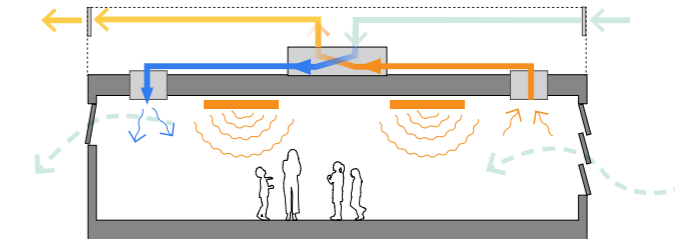

Electric ceiling radiators and ducted mechanical heat recovery. Natural ventilation during summer.

Alternative 01

This option may be used where site conditions require a different approach. Your project team will work with you to confirm whether this will work for your building and layout, and whether it is needed, based on site constraints, or existing infrastructure.

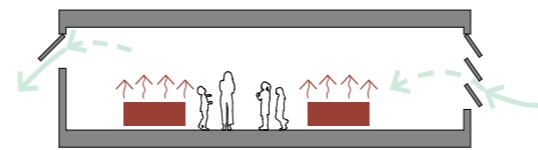

Airsource heat pumps and wall radiators with natural ventilation.

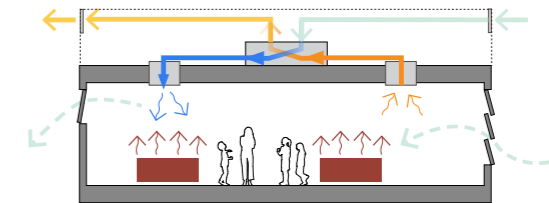

Airsource heat pumps, wall radiators and ducted mechanical heat recovery. Natural ventilation for summer.

Alternative 02

This option is used only in specific situations where other approaches are not suitable.

Because of upfront and ongoing cost, this option should be supported by a clear reason as part of the project process.

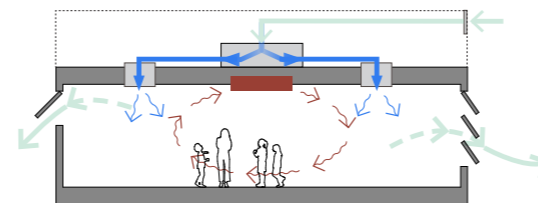

Heatpump VRF-AC cassettes and ducted outdoor air supply. Natural ventilation openings provided for optional use.

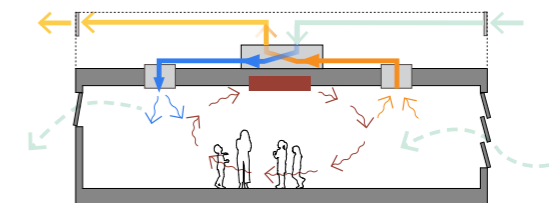

Heatpump VRF-AC cassettes and ducted mechanical heat recovery unit. Natural ventilation openings for optional use.

Working with you

Next steps & feedback

At each stage, your school plays a key role in shaping how standard designs are used to plan and deliver new school buildings.

If you have any questions about this guidance and how it relates to your school, please contact your school property advisor or project team. They can answer your queries and support you as needed.

Our goal is to continue improving the quality of school property, and we welcome your feedback. Contact us at:

property.improvement@education.govt.nz



**He mea tārai e mātou te
mātauranga kia rangatira ai, kia
mana taurite ai ōna huanga**

**We shape an education system
that delivers equitable and
excellent outcomes**
